

WARNING

REMOVE VOLTAGE FROM OPEN DRY CONTACT BEFORE SERVICING STATION OR PANEL. CONNECTION TO LINE VOLTAGE ON DRY CONTACT WILL RESULT IN A SAFETY HAZARD FOR SERVICE PERSONNEL.

OPTIONAL 120V HOUR METERS

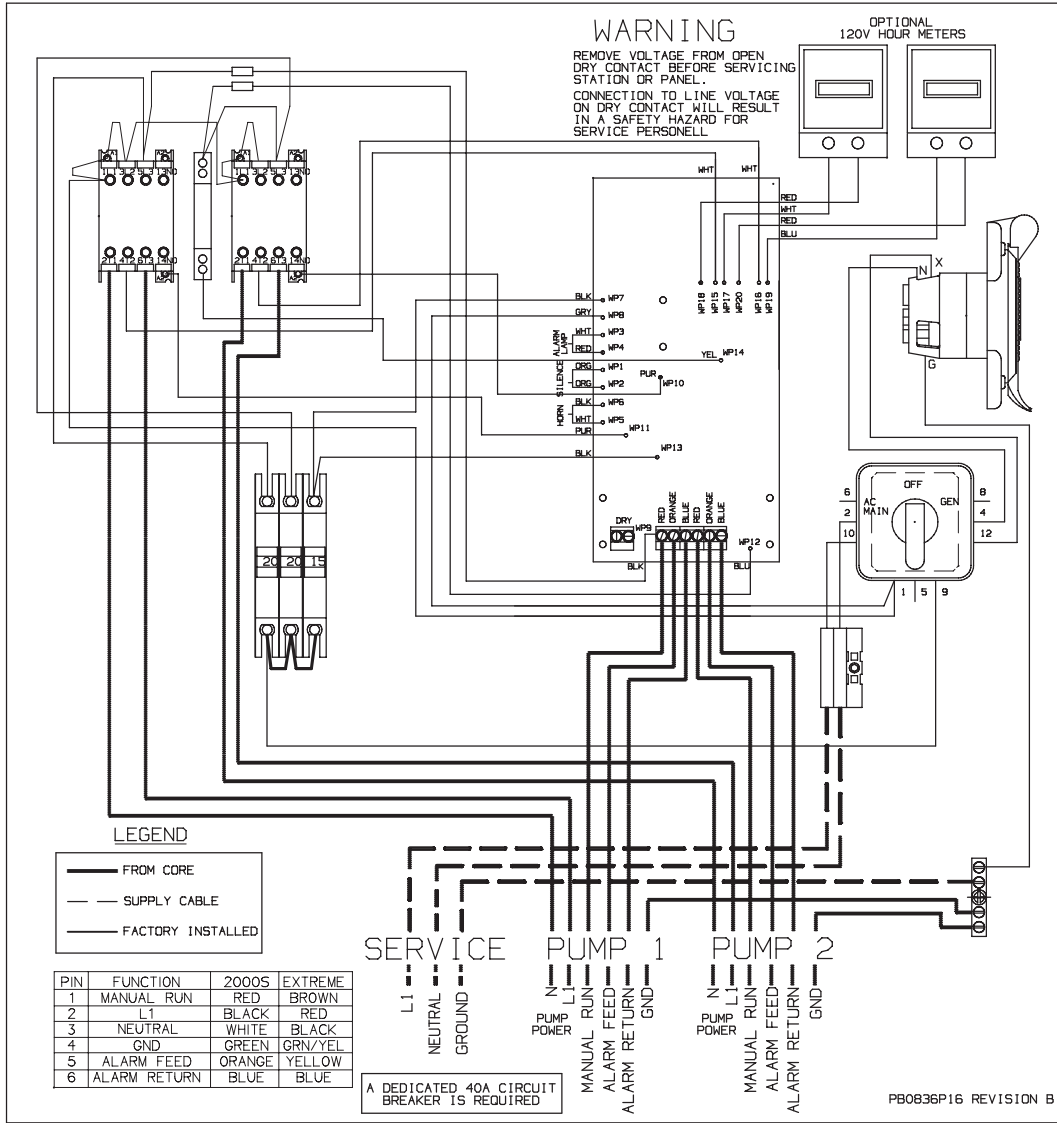

LEGEND

	FROM CORE
	SUPPLY CABLE
	FACTORY INSTALLED

PIN	FUNCTION	2000S	EXTREME
1	MANUAL RUN	RED	BROWN
2	L1	BLACK	RED
3	NEUTRAL	WHITE	BLACK
4	GND	GREEN	GRN/YEL
5	ALARM FEED	ORANGE	YELLOW
6	ALARM RETURN	BLUE	BLUE

SERVICE

L1
NEUTRAL
GROUND

PUMP 1

N
PUMP POWER
L1
MANUAL RUN
ALARM FEED
ALARM RETURN
GND

PUMP 2

N
PUMP POWER
L1
MANUAL RUN
ALARM FEED
ALARM RETURN
GND

A DEDICATED 40A CIRCUIT BREAKER IS REQUIRED

PB0836P16 REVISION B